

SeaBeacon Subsea Fibre Optic Connectors

The SeaBeacon range of Fibre Optic connectors is based on proven, commercially available, Expanded Beam (EB) inserts which are available in 10 configurations from 1 to 8 contacts in a Hybrid electro-optic set with options for 16AWG power and /or 20AWG signal channels.

The Expanded Beam interconnect solution offers significant benefits over traditional Physical Contact (PC) technology for harsh environment applications. The use of lenses for non-contact signal transmission makes them less susceptible to damage, contamination and easy to clean. Being less prone to the effects of Angular and Lateral misalignment result in greater stability in the most challenging of environments.



The design is suitable for singlemode and multimode (50/125µm and 62.5/125µm) applications and is offered with connector (CCP and CCR), through hole bulkhead (BCR) and flanged (FCR) housings. Rated to 6000m, these products can be supplied Oil filled, moulded in Polyurethane or Polyethylene or unterminated for field installation. Made from stainless steel as standard, connector bodies can be supplied in other materials to suit customer requirements.

Standard Inter-Connect Options

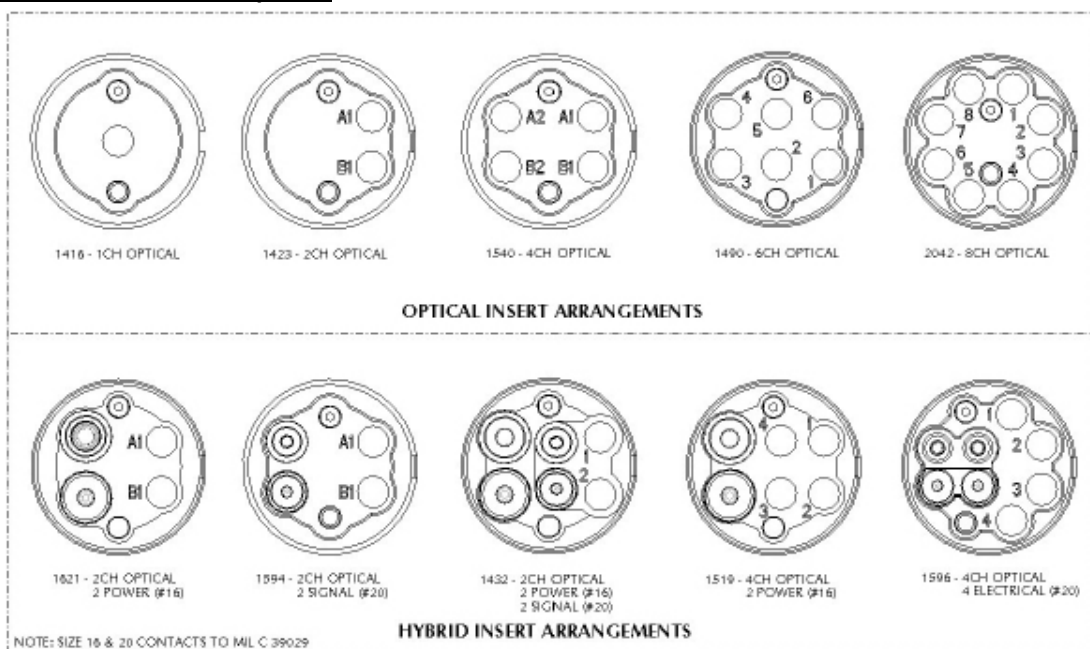

Provisional Specifications

Insertion Loss - Singlemode	2.0dB max. (9/125 μ m Fibre, 1310/1550nm)
Insertion Loss - Multimode	1.0dB max. (50/125 μ m Fibre, 850/1310nm)
Operating temperature	-40°C to +85°C
Storage temperature	-55°C to +85°C
Mating Cycles	>1000 (Optical)

Threaded Bulkhead (BCR) Dimensions

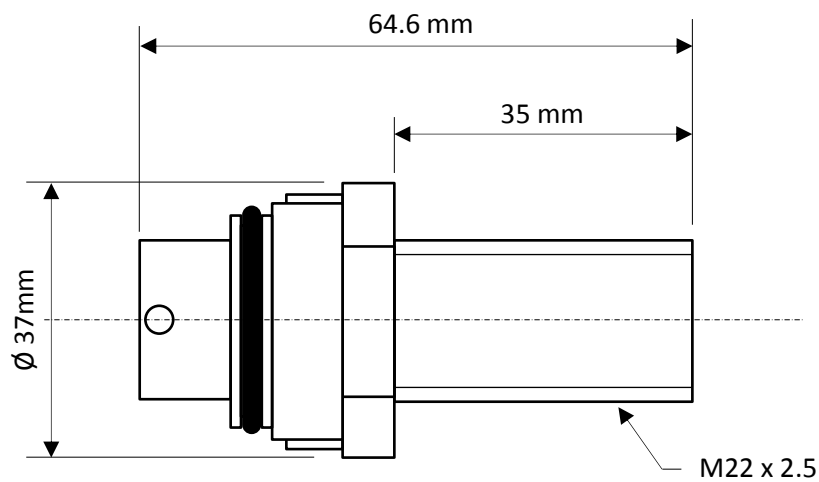

Moulded Connector (CCP) Dimensions

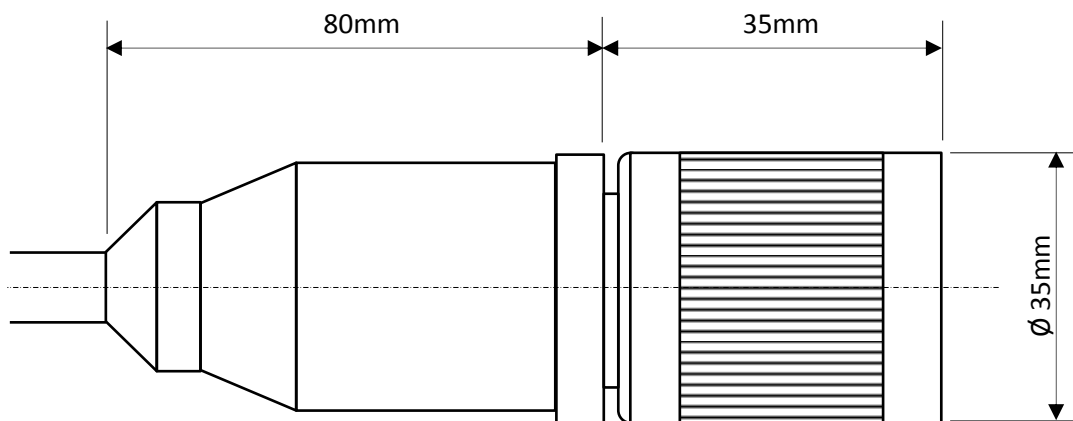

Expanded Beam Technology Overview

The traditional, physical contact design of fibre optic connectors rely on ceramic termini physically mating under spring pressure within an alignment sleeve for low loss transmission of light. Whilst this is a cost effective, low loss method it is not ideally suited to harsh environments where minute particles of dirt or contamination can damage the interface or obscure light transmission. Cleaning of termini is difficult and can often cause further damage requiring retermination. The precise co-axial alignment requirements of PC interconnects are sensitive to vibrations and rapid temperature changes :-

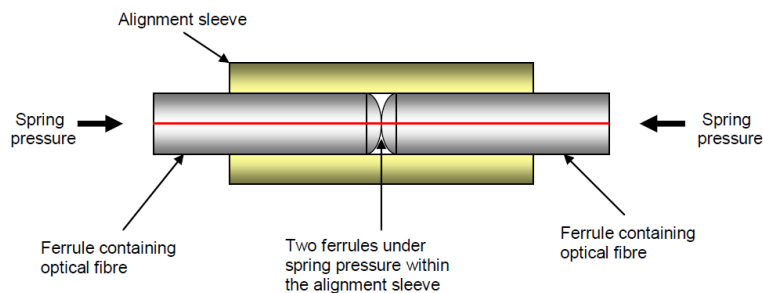

Expanded Beam connectors utilise lenses to expand and collimate light exiting from one fibre across a small air gap to a second lens which collects and refocuses the beam into the mating fibre :-

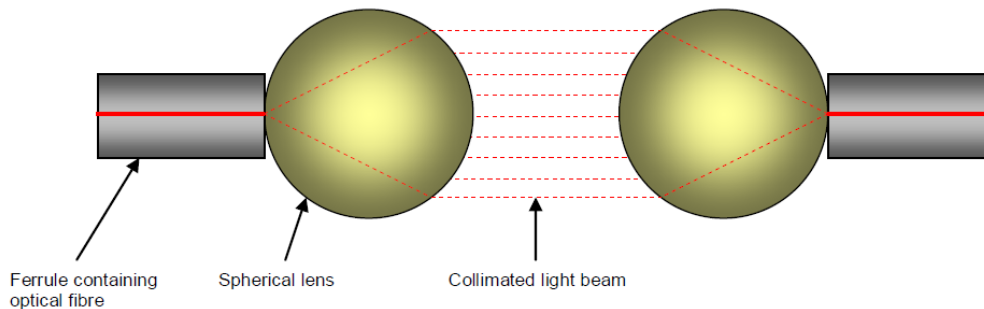

The effect of increasing the beam diameter (by around 2000 times for a singlemode fibre) makes the interconnect far less sensitive to dust or contamination :-

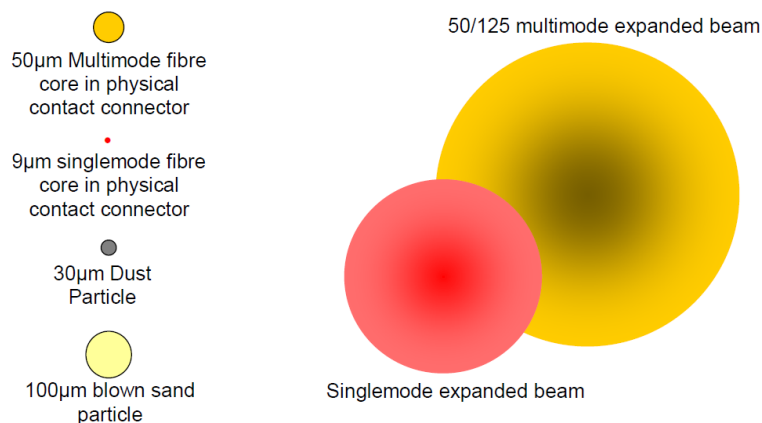

STSubsea products are being used in a wide variety of marine and harsh environments, including :-

- Subsea instrumentation, sensors, and control systems
- Autonomous and remotely operated surface and underwater vehicles
- Downhole instrumentation and logging systems
- Military Communication and Control systems
- Meteorological Buoy systems
- Military Sonar systems
- Land and Marine Seismic equipment
- Offshore renewable energy projects

These products are derived from a range of key strengths, capabilities and industry experience :-

- Specialised, bespoke connectors and cables for underwater or harsh environments
- Complete prototyping service, from design to manufacture to electrical and pressure testing
- Design of electrical, optical, coax /RF, Ethernet or hybrid connectors from unique one-offs to volume applications
- Cost effective, shallow water products
- Incorporating proven, commercially available interconnects into subsea capable solutions
- On-site moulding service and an over-moulding material capability for Polyurethane, Neoprene and Polyethylene components
- Through-hull penetrators, glass-to-metal seals and epoxy waterblocks
- Ceramic transducers and hydrophones
- Potting and encapsulation of switches, sensors, strain gauges and PCBs
- Long established, MetOcean range of metal shell, drymate connectors

STSubsea is a Division of STS Defence, providers of electronic manufacturing and through-life system engineering services; engaging with our customers through experience, expertise and a commitment to quality.

An SME based in Gosport, Hampshire, STS Defence focuses on customer value and satisfaction, working in partnership with customers to develop initial concepts into reality with divisions to match the needs of our customers:

Engineering Services delivers innovative solutions in the integration and support of maritime communication, multimedia and sensors for the UK defence market.

Manufacturing Services has an extensive aerospace, maritime, defence and commercial portfolio of capabilities in box build, PCB assembly, cable and harness manufacture and fabrication.

STSubsea Nuclear provides specialist support and training to civil and defence nuclear sectors.

Recently launched, IntelliMon focuses on intelligent monitoring systems for industrial, maritime and public safety applications.